

LP444s

USER MANUAL

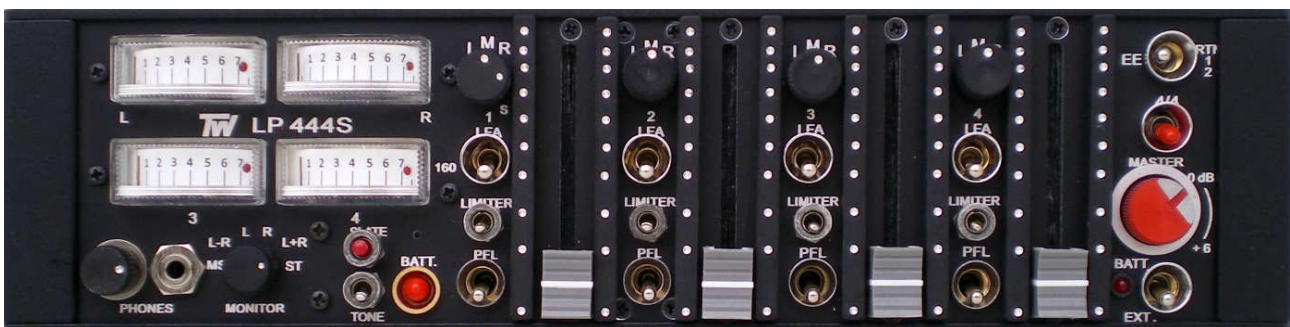

TW LP444s is a compact portable **4 in / 2 out** and switchable **4 in / 4 out** unit designed for four-track recorder or camera.



LEFT SIDE PANEL

- **Balanced channel inputs** – four electronically balanced circuits (transformer balanced is optional) in phase with one another. XLR connectors should be wired as pin1 ground, pin2 +phase signal and pin3 –phase signal.
- **Microphone powering selector switches** – The input sensitivity in position D is DYN 200 = 0.2 mV and no power. Selected 48, 12, T, mic powering, 10 dB of attenuation is automatically introduced, considering the sensitivity of condenser mics.
- **Phase reverse switches** – Intended to compensate for a phase error due to wiring or mic placement.
- **Phantom on / off switch** – The current consumption of the phantom power supply is 13 mA. Phantom power supply may be switched off (only if using dynamic, wireless or T powering mics) to increase the lifespan of the internal batteries between two chargings.
- **Attenuation switches** – The gain of the mic preamplifiers may be decreased by –10 dB in position D. In positions 48, 12 and T the attenuation is –13 dB.
- **Mic / line level switches** – Selects mic or line to add –60 dB attenuation before the mic preamplifiers.
- **Optional NP1 Battery Holder** – The switched mixer supply is derived either from the internal AA batteries or from NP1 battery depending on the position of the panel side switch.

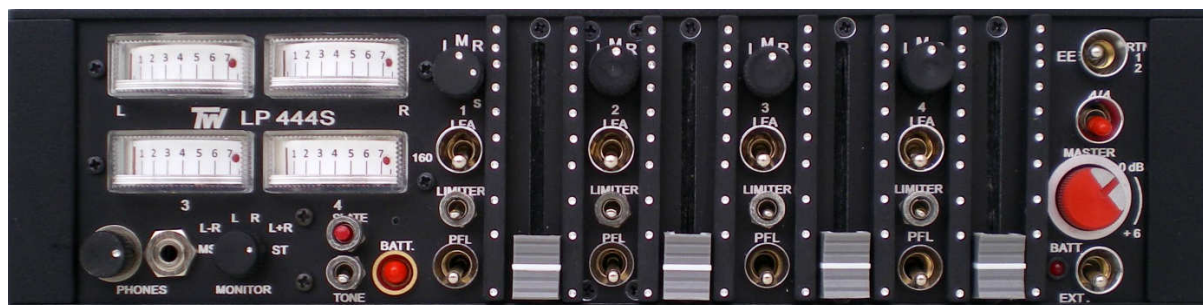

FRONT PANEL

- **4 / 4 switch** – The TW LP444s mixer works in stereo mode when this switch is turned down. Turned to 4 / 4 position, channel 1 Pan switched in L, channel 2 in R, the four inputs can be controlled independently by the channel faders to the four outputs.
- **Modulometers** – Continuous lighting, peak reading, BBC 1-7, dB or VU scaling, built-in red LEDs indicate when the gain reduction is occurring with the limiters switched on.
- **6.3 and 3.5 mm phone jacks**
- **Monitor selector switch** – ST stereo. L+R sum signals, phase check, MS stereo equivalent Left. L–R difference signals MS stereo equivalent Right. MS matrix, MS stereo equivalent. R right channel. L left channel. Channels L and 3, channels R and 4 are linked for the monitor circuit in 4 / 4 mode.
- **Phones volume control** – Output voltage into 50 Ω adjustable from 20 to 500 mV.
- **Limiters on / off switches** – The four individual limiters have fast attack time (less than 1 msec) and a slow release time to smooth operation. Two red LEDs are built in the meters to indicate – depending on meter selector switch – when the limiters are selected and gain reduction is occurring. Threshold is internally set to +6 dBu at the balanced output. To adjust the limiter threshold for a value different from the supplied +6 dBu, see page ADJUSTEMENT POINTS.
- **Battery check pushbutton** – R meter shows the battery status 6/full 5/power LED starts to blinking and after the battery gets empty.
- **Reference generator switch** – 1 kHz sine wave signal is fed to all four outputs and the level can be controlled at L and R outputs by the Master control but channel 3 and 4 outputs are internally set to 0 dB.
- **Slate microphone** – It can be used either for identifying recorded segments or as an emergency field microphone.
- **Low-cut filter switches** – Low frequency attenuation is 14 dB / octave at 100 Hz.
- **Pan switches** – Assign selected input signal to Left or Right output. In M position, equal amount of signal is sent to Left and Right outputs. The S position of Pan switch 1 assigns Channels 1–2 as a stereo pair controlled by Channel 1 Fader.
- **Channel gain controls**
- **Pre-Fade Listen pushbuttons** – Each channel can be checked by monitoring. Output audio signal is not interrupted when the PFL pushbutton is activated.

- **EE / RTN12 switch** – A two-position switch selects the direct outputs from the mixer or the return 1 and 2 as a signal source for the monitoring.
- **Master** – The fader sets the gain of both Left and Right legs and has +6 dB of gain in hand with the nominal 0 dB gain position marked.
- **PWR LED** – A red LED lights to indicate power is on, and blinking when the battery is too low.
- **Power switch** – In position EXT the mixer will be powered by an external DC supply and in BATT by the internal batteries. Batteries should be recharged with the switch in EXT position.



RIGHT SIDE PANEL

- **Balanced outputs** – The four main outputs are via transformer balanced XLR connectors. Left and Right outputs are linked a Hirose 10pin multiway connector to facilitate rapid connection of outputs and monitor returns. The line level is set on 600 Ω at 0 dBu and +4 dBu for VU metered mixers. The Hirose 10pin connector is wired as follows:

pin 1. +LEFT output	pin 5. RIGHT return
pin 2. –LEFT output	pin 6. N / C
pin 3. +RIGHT output	pin 7. LEFT return
pin 4. –RIGHT output	pin 8. N / C
pins 9., 10. GROUND	

- **Unbalanced Post Fader outputs** – A TA5M 5pin connector carries four unbalanced output signals – at a level 3 dB lower than balanced outputs – to feed a recorder. The connector is wired as follows:
pin1-CH1 out pin2-CH2 out pin3-CH3 out pin4-CH4 out pin5-GROUND

- **Direct Channel Pre-Fader Outputs** – via a TA5M connector, that is wired as follows:
pin1-CH1 out pin2-CH2 out pin3-CH3 out pin4-CH4 out pin5-GROUND

- **Line / mic level switches** – The line level at XLR and Hirose connectors can be attenuated by 50 dB to provide the microphone level.

- **3.5 mm stereo monitor input jack**

- **Video assist** – A mono output formed by summing the Left, Right, Channel 3 and Channel 4 output channels is also available on a TA3M connector. It is an unbalanced signal at 3 dB below the level of unbalanced output. The connector is wired as follows:

pin1. GROUND	pin3. SIGNAL
--------------	--------------

- **Return 1 or 2 selector switch** – In position RTN1 the 3.5 jack and Hirose returns are chosen for monitor, switched to RTN2 the returns of RTN2 3.5 jack will be fitted by the monitoring circuits.

- **Power supply** –The DC power stabiliser of TW mixer has built-in Poly-Fuse to protect the unit. If a problem occurs that trips this fuse, it will reset after the power supply is disconnected for about 15 seconds. The mixer may be powered by 12 pieces internal AA size rechargeable batteries or an external DC supply 12-24 Vdc. Fully charged batteries will typically power the mixer for 8 hours at continuous use. The external XLR 4pin connector is wired as follows:

pin 1., 2. GROUND	pin 3. Battery Charge	pin 4. External 12-24 Vdc
-------------------	-----------------------	---------------------------

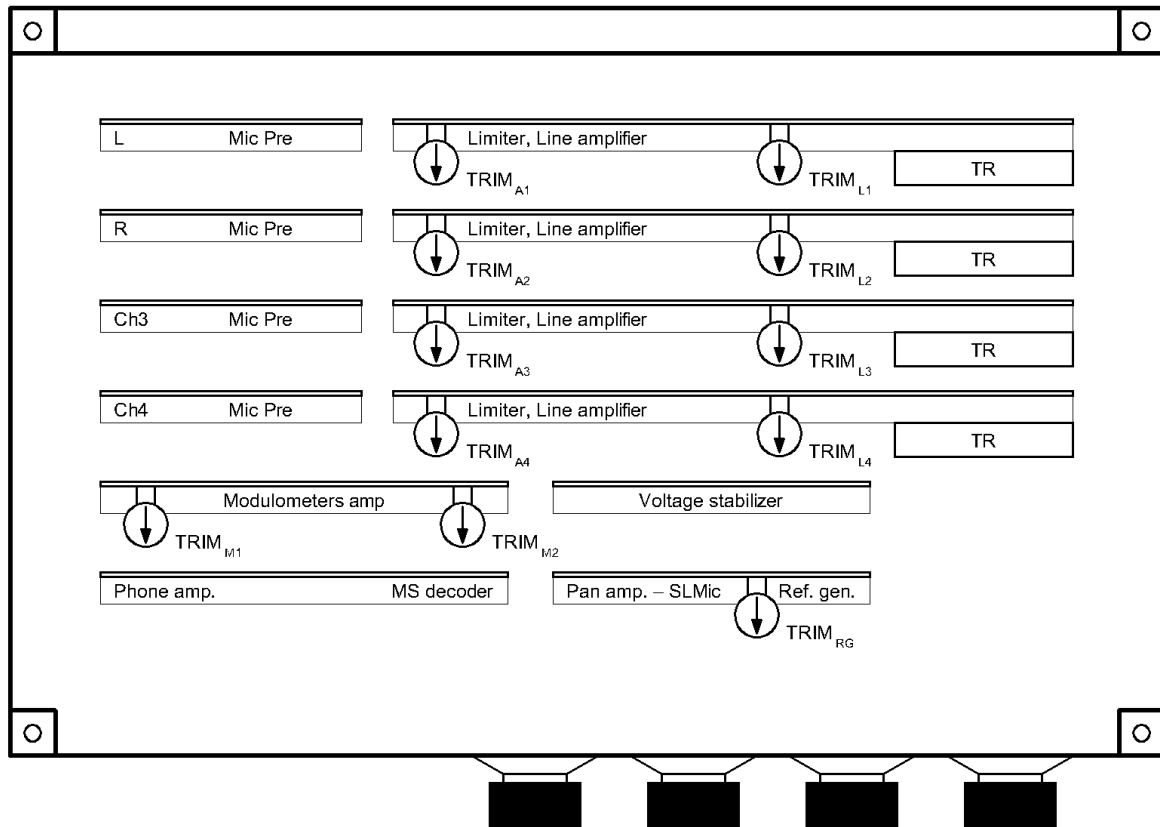

ADJUSTMENT POINTS

- Gain and modulometer adjustment** – Connect an AC voltmeter to the Left balanced line output. Set channel 1 pan switch to L position, turn channel 1 fader fully clockwise, set Master at marked 0 dB and switch LFA off. Connect an audio generator 1 kHz 0 dBm attenuator -80 dB to Mic 1 Input and adjust $TRIM_{A1}$ to obtain 0 dBu (+4 dBu on VU metered mixers) at the Left balanced output. Then adjust $TRIM_{M1}$ on Modulometer amplifier board to obtain 0 dB on the Left meter. Cut off the input signal and switch on the Reference Generator. Adjust $TRIM_{RG}$ on Ref. Gen amplifier board to obtain 0 dB at the Left meter. Repeat it for Right output and Right meter, that turn up 4 / 4 switch and put meter selector switch to 3–4 and repeat the setting for Channel 3 and Channel 4 outputs.

- Limiter threshold adjustment** – Connect an AC voltmeter to the Left balanced line output. Apply a 1 kHz signal until the AC voltmeter reading is at the level desired with limiter switched off. Move the limiter switch in position LIMITER and adjust $TRIM_{L1}$ until the level drops 0.5 dB. Repeat it for Right output and Right meter then turn up 4 / 4 switch and put Meter selector switch to 3–4 and repeat the setting for Channel 3 and Channel 4 outputs.

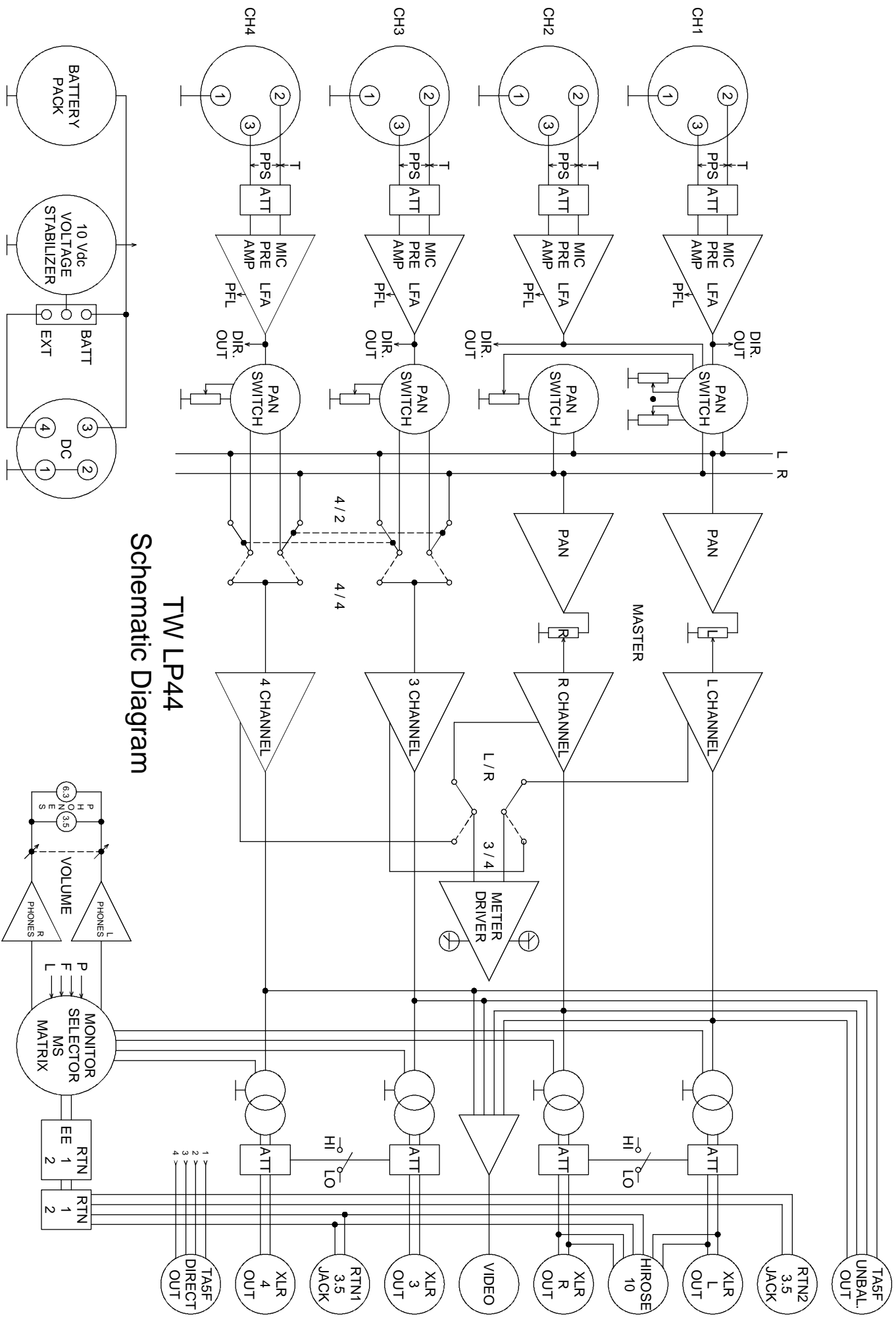

TW LP44
Schematic Diagram

SPECIFICATIONS

• Inputs

Microphone: four balanced XLR female
Sensitivity: -75 dBu
Maximum input level: -20 dBu
Microphone power: 48 V, 12 V, T (DIN AB)
Line attenuation: adds 60 dB attenuation before the mic preamp.
Signal to Noise ratio: > 65 dB, Equivalent Input Noise: -125 dBu
Frequency response: 20 Hz - 20 kHz \pm 2 dB
Harmonic distortion: less than 0.2 %
Low-cut filter: 80 / 100 Hz / 14 dB octave
Crosstalk isolation, channel to channel: < -65 dB

• Outputs

Line: transformer balanced XLR
Line level on 600 Ω 0 dB on the modulometer: +6 dBu
4 on the 1-7 scaling: 0 dBu
0 Vu on the VU scaling: +4 dBu
Unbalanced line and monitor returns
Maximum output level: +18 dBu

- Internal power: battery
- External power: 11-25 Vdc
- Power consumption: 90 mA
- Dimensions: 255 x 165 x 65 mm (10 x 6.5 x 2.6 in)
- Weight: 2 kg (4.2 lbs)



ELECTRONIC COMPONENTS

Kaptárkő u. 11.
Budapest H-1118
HUNGARY
www.twelco.hu

phone.: +36 1 783 7282
mobil: +3620 526 9843
e-mail: twelco@upcmail.hu